



# TECHNICAL DATA

FROM

# Anemostat

## Door Products

4958 Stout Dr. #119, San Antonio, TX 78219  
 PH: 210.662.6300 • FAX: 210.662.2828

e-mail: [door@anemostat.com](mailto:door@anemostat.com) • website: [www.anemostat.com](http://www.anemostat.com)

# BFL-75

METAL  
VISION FRAME



UNDERWRITERS'  
LABORATORIES

FIRE  
RATINGS



WARNOCK  
HERSEY

**B.S.-476.22**  
British Standard

### DETAIL DRAWING

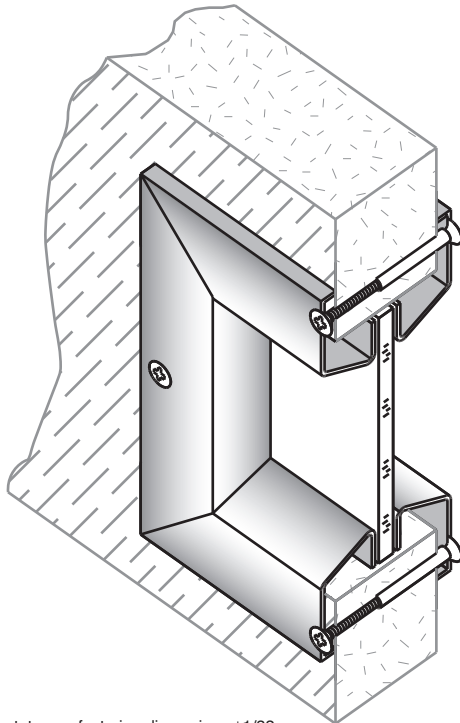

Anemostat manufacturing dimensions  $\pm 1/32$   
 Actual dimensions are nominal and may vary  
 based on component manufacturers tolerances.

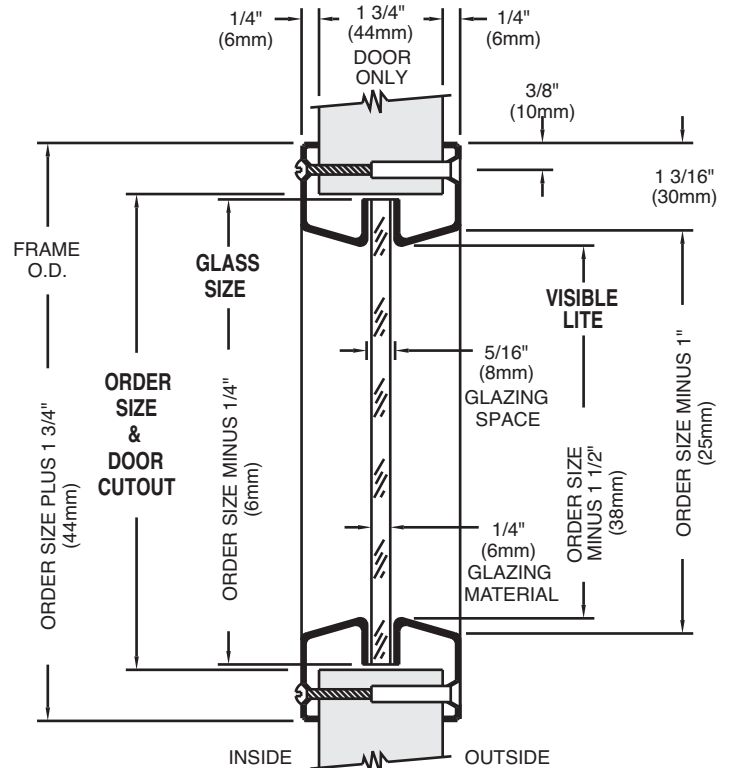

### STANDARD PRODUCT FEATURES

- **MATERIAL:** 18 GA. (1.25mm) Cold Rolled Steel.
- **FINISH:** Grey Primer, Beige or Bronze Baked Enamel.
- **INSTALLATION:** By drilling 1/4" (6mm) holes thru the door, around the perimeter of the door cutout. Frame has countersunk mounting holes for #8x32 phillips head steel thru bolts with a blank head on one side for flush appearance.
- **DOOR THICKNESS:** For 1 3/4" (44mm) Wood or Metal Doors.
- **GLAZING:** Should be 1/4" (6mm) or 3/16" (5mm) fire and/or safety rated with U.L. and/or W.H.I. classification markings. Glazing space of 5/16" (8mm) allows for glazing tape to be used on both sides of the glass.
- **AESTHETICS:** Tight mitered corners, beveled glass stop for a clean tapered look.
- **IMPORTANT:** Interpretation of building and fire codes may vary. Consult with the local authority having jurisdiction in your area, to determine appropriate standards.
- **NOTE:** For Exterior use, High Humidity or Salt Air application, product must be Galvanized or Stainless Steel.
- **PLEASE NOTE:** On visible lite sizes larger than 1296 sq. in. (0.836m<sup>2</sup>) on 20/45 min. and 100 sq. in. (0.065m<sup>2</sup>) on 60/90/180 min., please consult with your Door / Frame Manufacturer's procedures, for their maximum glass size tested.

### OPTIONAL FEATURES

- **MATERIAL:** #304 or #316 Stainless Steel, #4 Finish(Satin), Galvanized (Coil, Hot Dipped, or Zinc Plated).
- **FINISH:** Custom Baked Enamel Colors (as per sample chip supplied). Plated Finishes to match the lock, hinges and closer.
- **FASTENERS:** Special Security Screw Fasteners, See Page 36, this section.
- **SPECIALS:** Fractional Sizes, Lead Lined for X-ray applications, Glass or Door thickness (see FGS-IS or LoPro-IS).
- **HM CLIP:** Replaces the need for reinforcing channel in the door cutout, see page 37 this section.

### FIRE RATINGS (w/ U.L. & W.H.I. classification markings) Positive Pressure

- **20 MINUTE:**\* Approved listing at 3204 sq.in. (2.067 m<sup>2</sup>) visible lite max. width 36" (914mm), max. height 89" (2261mm).
  - **45/60 MINUTE:**\* Approved listing at 2772 sq.in. (1.788 m<sup>2</sup>) visible lite max. width 36" (914mm), max. height 77" (1956mm).
  - **90 MINUTE:**\* Approved listing at 1296 sq.in. (0.836 m<sup>2</sup>) visible lite max. width 36" (914mm), max. height 54" (1372mm).
  - **3 Hour:**\* Approved listing at 100 sq.in. (0.065 m<sup>2</sup>) visible lite max. width 12" (305mm), max. height 33" (838mm)
- \* Must be used with FIRELITE Plus or NT and Fire listed glazing tape or another manufacturer's equivalent product. Glazing combination must be used in appropriately tested door assembly.

Job Name & Location	Submitted by